

RANGE
4WD
4 WHEEL DRIVE



 **SL90-20**
TRANSAXLE

SADEV
RACING TRANSMISSION

SADEV
RACING TRANSMISSION

RANGE
4WD
4 WHEEL DRIVE

SL90-20 TRANSAXLE

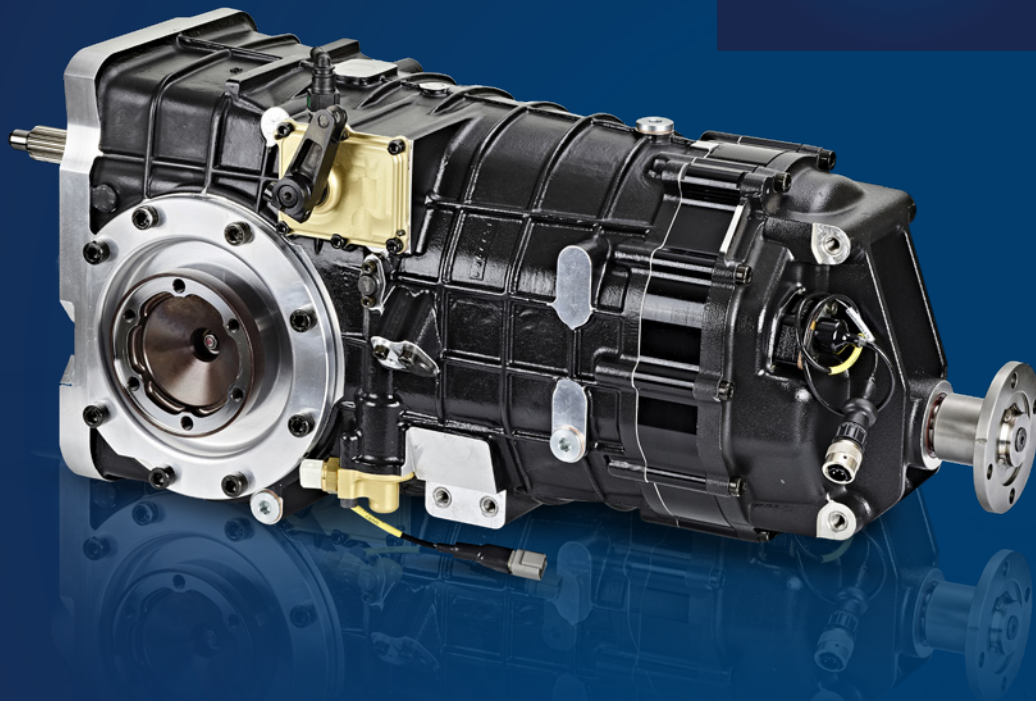

Flexibility is the best word to describe the **SL90-20** transmission. Its variety of adaptable parts enables us to build a gearbox tailored to your needs. As well as accepting heavy loads, it comes in several versions: with or without load-bearing casing, 4WD central engine, 4WD overhang engine.

APPLICATIONS

- › *Autocross*
- › *Circuit*
- › *Hill Climb*
- › *Ice Racing*
- › *Rallycross*
- › *Rally*
- › *Offroad rally*



TECHNICAL SPECS

6 speed sequential gearbox + 1 reverse gear

Manual sequential gear selection

Bevel gear ratio : 9x35 or 10x31

The bevel gear is cut and grinded in house on our CNC units

Wide range of ratios available

Straight cut gears

Dog ring gear engagement

Interchangeable gear ratios

High strength carburizing steel

Gear teeth grinded with optimized profile

Shot penning on internal parts

Specific input shaft

Limited slip differential

Ramp and plate system - 3 discs type

Preload made by spring washer

Wide range of ramp plates available

Reverse lockout cable (solenoid system optional)

Flat shift sensor

Splash lubrication system

Magnetic drain plugs

Painted AS7G aluminum casings

Case joint faces sealed with O'rings

Weight (input shaft included) : 67 Kg - 148 lbs

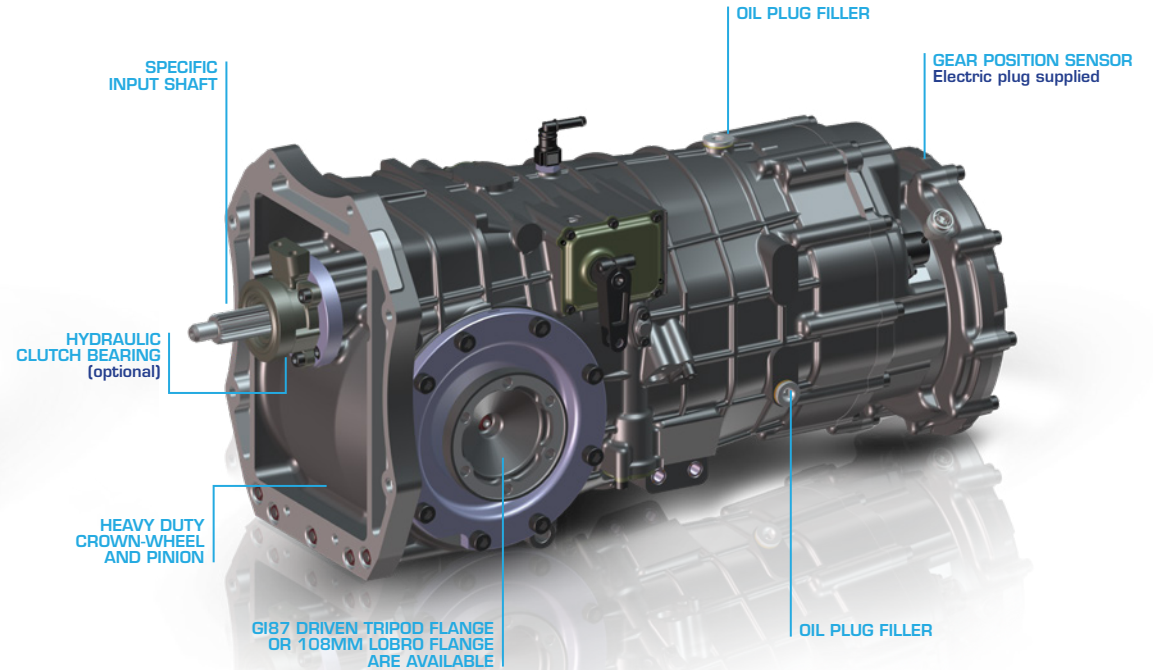
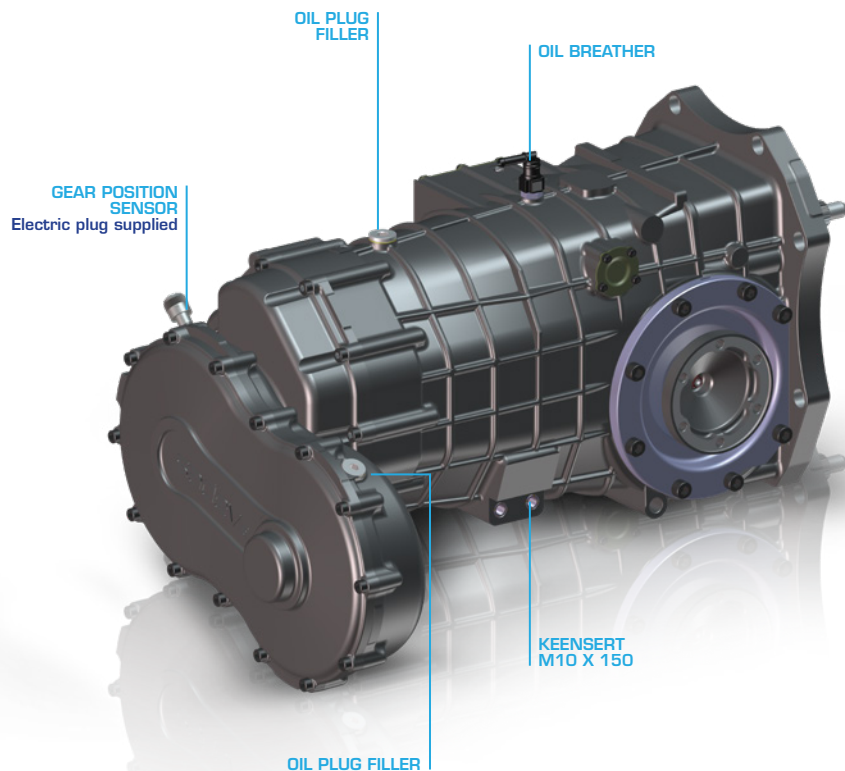

ACCESSORIES

- › Gear display
- › Mounting plate
- › Drive shafts
- › Propshaft

ALL WHEEL DRIVE VERSION
WITH TRANSFER CASE

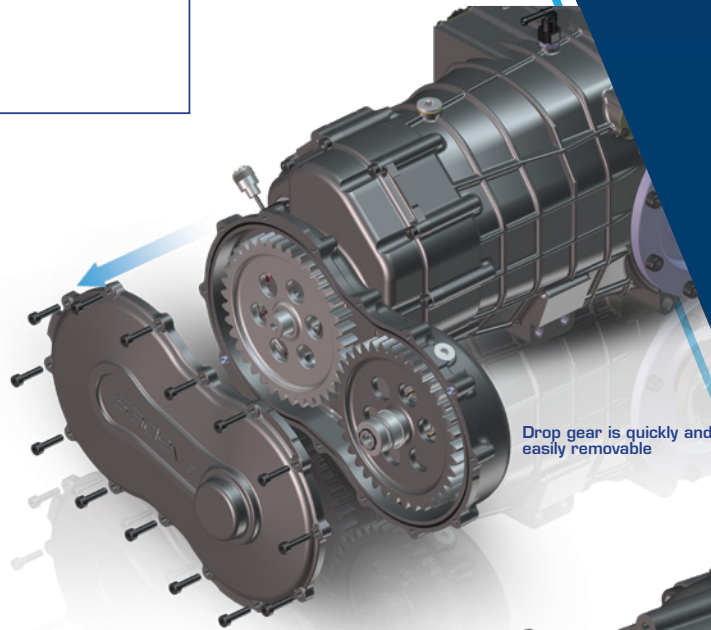

Drop gear is quickly and easily removable

OVERHANG ALL WHEEL
DRIVE VERSION

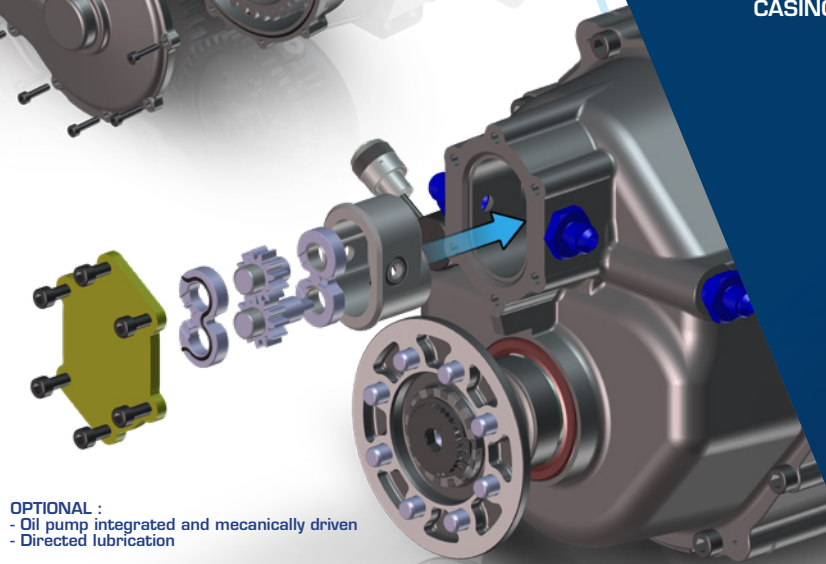

OPTIONAL :
- Oil pump integrated and mechanically driven
- Directed lubrication

OVERHANG ALL WHEEL DRIVE VERSION WITH SUBARU
FRONT CASING

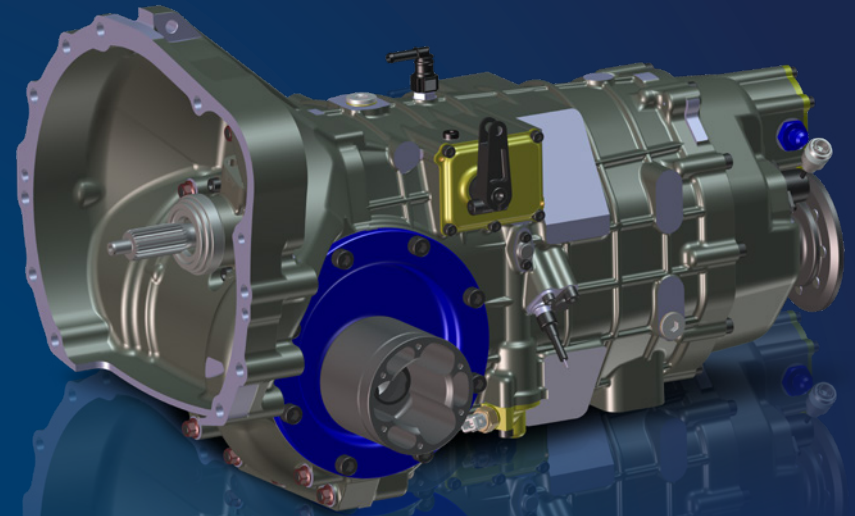

OVERHANG ALL WHEEL DRIVE
VERSION WITH STANDARD
CASINGS

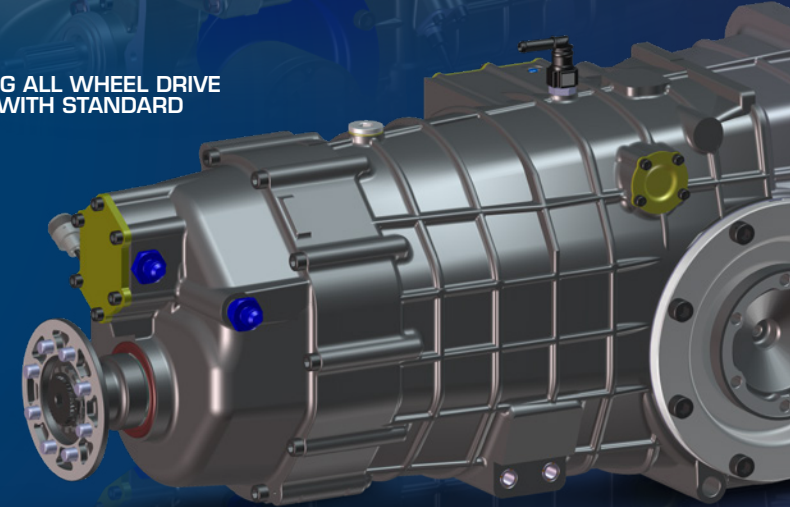



SL90-20 TRANSAXLE

- › **Gears:** The **SL90-20** benefits from optimised gear tooth profiles for maximum efficiency.
- › **Ratio selection:** Optimised clutch and control shaft definition for smoother gear shifting.
- › **Limited slip self-locking ramp differential:** Wide choice of ramps and preload washers for precise, detailed adjustment.
- › **Cooling:** An oil pump can be connected to the **SL90-20**. Driven mechanically, this enables an external oil cooler to be connected.
- › **Robustness:** Our finite element calculation tool enables us to design extremely strong, compact, lightweight casings.
- › **Adaptability:** With its many possible configurations, the **SL90-20** is a highly developed product that adapts perfectly to your vehicle and your application.

MAXIMUM ENGINE TORQUE

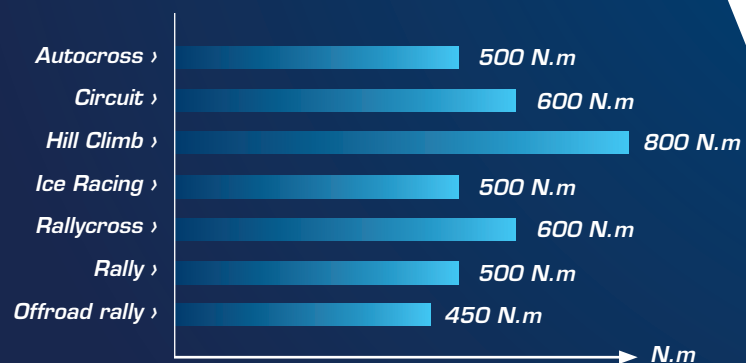



**ONE PASSION:
VICTORY**

SADEV has an exceptional record in supplying unique engineering to the most prestigious drivers and manufacturers. SADEV's products stand out for their technology, their excellence and their ambition. As precise as they are reliable, these high-tech masterpieces are the key to your victory. SADEV has just one goal: to make sure you win.

FOLLOW US



WWW.SADEV-TM.COM

6, rue Grand'Montains - 85110 SAINT-PROUANT - FRANCE

Tel: +33 (0)2 51 66 42 68

sadev@sadev-tm.com



A TEAM AT YOUR SIDE

- FRANCE** SADEV FRANCE - sadev@sadev-tm.com
- USA** SADEV TRANSMISSIONS, INC. - info.usa@sadev-tm.com
- UK** SWR MOTORSPORT LTD - servicesswrmotorsport@gmail.com
- ITALY** GIEFFE RACING - info@giefferacing.com
- SPAIN** DE LA PUENTE MOTORSPORT - dlpmotorsport@movistar.es
- NETHERLANDS** RACING DEVELOPMENT - info@racingdevelopment.nl
- NETHERLANDS** PETERS AUTOSPORT - bart@petersautosport.nl
- BELGIUM** R TEC - info@rtec.ws
- CZECH REPUBLIC** SADAC - info@sadac.cz
- GERMANY** MTO ENGINEERING - info@mtoengineering.com
- SWEDEN** HANSEN MOTORSPORT - kenneth@hansen-motorsport.se
- DENMARK** GUNNAR AASKOV MOTORSPORT - mail@aaaskov-motorsport.dk
- FINLAND** SET PROMOTION - kalle.pinomaki@setpromotion.com
- SWITZERLAND** CHRISTIAN FERRARI - ferrach@bluewin.ch
- SOUTH AFRICA** CENTURY RACING - julien@centuryracing.co.za
- ARGENTINA** JPO RACING - racingjpo@gmail.com
- BRAZIL** CD MOTORSPORT ENGINEERING - sadev.brasil@gmail.com

